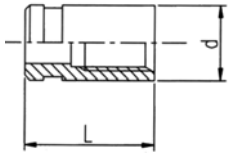
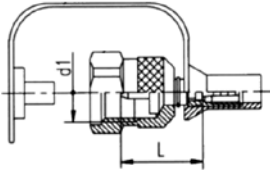

# MEASURING SYSTEMS - hose fittings

Fittings described below are designed for 2x5 mm hose (801 type) and 4x8 mm (804 type). To select proper fittings for hoses with different diameters, please contact TUBES INTERNATIONAL® Technical Department.

Crimping ferrule			
			
<b>800.00</b>			
press. [bar]	code	L [mm]	d [mm]
-	PS-800-00-002-00	14	8
	PS-800-00-004-00	17	11.5

Test fitting. female thread			
			
<b>801.10</b> <b>804.10</b>			
press. [bar]	code	L [mm]	thread size d1
630	PS-801-10-161-00	22	M16x1.5
	PS-801-10-162-00	22	M16x2
	PS-810-10-162-00*	22	M16x2
500	PS-804-10-162-00	22	M16x2

\* - AISI 316 steel

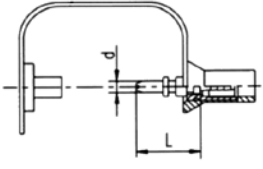
Test fitting. push-in connection			
			
<b>801.20</b>			
press. [bar]	code	L [mm]	d [mm]
400	PS-801-20-000-00	19	3.3

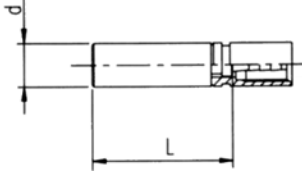
Pipe fitting			
			
<b>801.30</b> <b>804.30</b>			
press. [bar]	code	L [mm]	d [mm]
-	PS-801-30-004-00	26	4
	PS-801-30-006-00	25	6
	PS-801-30-008-00	25	8
	PS-804-30-004-00	29	4
	PS-804-30-006-00	29	6
	PS-804-30-008-00	29	8

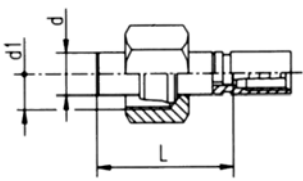
Pipe fitting, female thread (with cutting ring), 24° cone				
				
<b>801.31</b> <b>801.32</b>				
press. [bar]	code	L [mm]	d [mm]	thread size d1
315	PS-801-31-006-00	26	6	M12x1.5
630	PS-801-32-006-00	26	6	M14x1.5
315	PS-801-31-008-00	26	8	M14x1.5
630	PS-801-32-008-00	26	8	M16x1.5

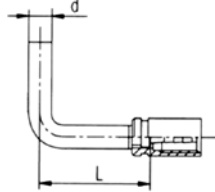
90° elbow pipe fitting			
			
<b>801.35</b>			
press. [bar]	code	L [mm]	d [mm]
-	PS-801-35-004-00	23	4
	PS-801-35-006-00	22	6
	PS-801-35-008-00	31	8